

Benefits of Using the Albion Process for a North Queensland Project, and a Case Study of Capital and Operating Cost Benefits Versus Bacterial Oxidation and Pressure Oxidation

Authors: M. Hourn ¹, P. Rohner ², P. Bartsch ³, K. Ngoviky ³

¹ Xstrata Technology, ² Core Resources, ³ Aker Kvaerner Australia

1. Abstract

With increasing levels of gold production coming from refractory sulphide ores and a chronic skills shortages in the mining industry there is a need for a simple, robust and lower cost treatment route for refractory gold ores.

Xstrata and Highlands Pacific have recently agreed to offer their Albion Process technology under license as a new lower cost alternative to existing refractory gold treatment technologies. Core Resources, a company founded by former Xstrata executives, has entered into arrangements to undertake further development and commercial licensing of the Albion Process technology.

As part of this commercialisation process, Aker Kvaerner Australia (AKA) worked in partnership with Core Resources to carry out a comparative capital and operating cost study using three different refractory gold treatment technologies for the gold ores of an advanced exploration project in North Queensland, Australia. This paper provides background to the Albion Process along with a summary of the benefits of using this novel technology at the North Queensland project, compared with bacterial oxidation or pressure oxidation. It also draws on AKA's extensive knowledge of bacterial and pressure oxidation plants and provides qualitative and quantitative assessments of the different technologies.

2. Introduction

Xstrata's Hydrometallurgical Research Laboratories was commissioned by the owner of the North Queensland project to conduct pre-feasibility metallurgical testwork on ore samples from the project. The upgraded flotation concentrate samples were tested using pressure oxidation, bacterial oxidation and the Albion Process.

Parameters from this testwork provided the basis of the design criteria for the study into a refractory gold treatment plant with a scale of approximately 100,000 oz/yr of gold, using each of these technologies.

The testwork was intended to determine the recovery performance of the North Queensland ore from each of these technologies and then to provide comparative data on operating and capital costs.

3. Albion Process – A New Lower Cost Technology

Metals such as copper, nickel, zinc and gold may be recovered from ores or concentrates by hydrometallurgical techniques, which involve the leaching of the valuable mineral in a chemical solution. In some instances, the mineral containing the valuable metal can not be leached efficiently using conventional techniques, and the mineral is called *refractory*.

Modern methods for liberating valuable metals from refractory minerals have involved complex processing of the minerals at high temperatures and/or pressures to facilitate leaching. These methods, such as roasting and pressure leaching, are capital intensive and, in the case of roasting, produce environmentally damaging effluent streams, requiring further processing. Other processes such as bio-oxidation are also capital intensive and difficult to manage.

The Albion Process is a highly attractive process to treat refractory sulphide minerals to recover valuable metals housed in the sulphide lattice. The process consists of ultrafine grinding of the mineral, followed by oxidative leaching at atmospheric pressure in open tanks. The flowsheet utilises existing, commercially proven technology in its unit operations. The Albion Process is therefore an important technical breakthrough.

The Albion Process was developed by MIM Holdings (now Xstrata) and a former MIM subsidiary Highlands Gold, to treat refractory base metal and gold ores. The technology has been tested extensively at pilot plant scale. The Albion Process is currently being evaluated for use in several world class mining projects by Xstrata, as well as by companies external to the Xstrata group.

The process was initially designed to operate under acid conditions for the extraction of base metals, possibly with precious metals by-products (the “Acid Process”). However during the development process, it was recognised that oxidation of pyrite (and tellurides) could be achieved more effectively under alkaline conditions, and that this was well suited to treatment of precious metals ores containing mainly pyrite. This led to a parallel development of the technology for mainly refractory pyritic gold ores, with separate patents lodged for this branch of the technology (The “Alkaline Process”).

3.1 Description of the Albion Process technology

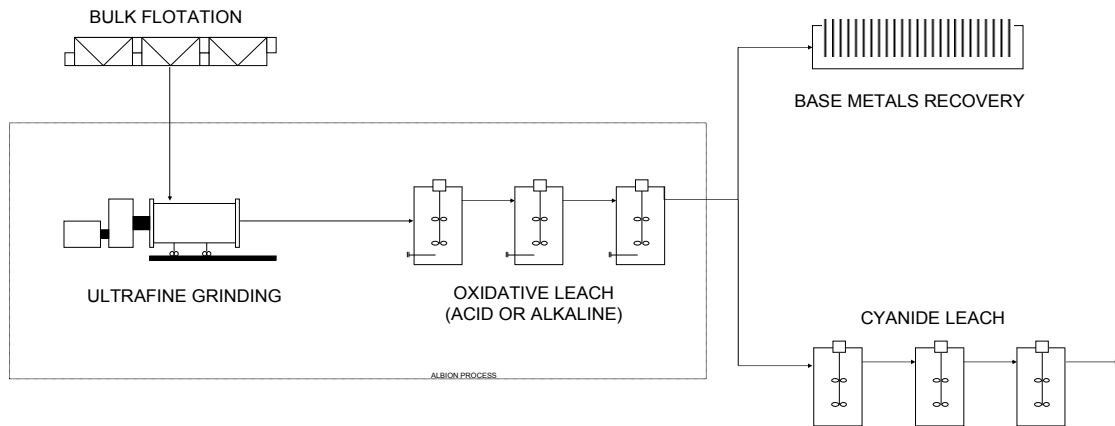

Figure 1 - Albion Process schematic flowsheet

3.1.1 Acid Process

The acid process is used to recover valuable metals such as copper, zinc, nickel and cobalt that are in the form of sulphide mineral concentrates. Precious metal by products such as gold can also be recovered from the leach residue.

The flowsheet involves oxidative leaching of a finely ground concentrate at atmospheric pressure. The process of ultrafine grinding, normally to 80 % passing sizes of below 20 microns, results in a high degree of strain being introduced into the mineral lattice which “activates” the mineral, facilitating leaching. The rate of leaching is also enhanced, due to the dramatic increase in the mineral surface area. Ultrafine grinding of sulphide minerals to a particle size of 80 % passing 8 – 12 microns will also eliminate passivation of the mineral by sulphur precipitates, as the leached mineral will disintegrate prior to the precipitate layer becoming thick enough to passivate the mineral.

Sulphide metals such as chalcopyrite, pyrite, or arsenopyrite are oxidised in the acid process, with ferric ions being the main oxidising agent.

The major leach reaction is:



As the leach is carried out at atmospheric pressure, sulphides are preferentially oxidised to elemental sulphur.

The resulting ferrous iron is re-oxidised by oxygen to regenerate the ferric ions:



Depending upon the feed mineral composition, some or all of the acid and the ferrous/ferric ions are obtained from dissolution of iron minerals (usually pyrite) in the feed. Metals such as copper may then be recovered by solvent extraction and electrowinning. Unwanted metals such as iron and arsenic are selectively precipitated and removed in a neutralisation stage following the leach. Contained gold (having been liberated through the oxidation of the sulphide minerals in which it was previously encapsulated), may be cyanide leached.

The process can be applied to the recovery of base metals such as copper, zinc, nickel and cobalt from sulphide concentrates.

3.1.2 Alkaline Process

The alkaline process is used to recover precious metals such as gold, silver and platinum group minerals that are present in refractory or carbonaceous ores that cannot be processed by standard cyanide leaching. The alkaline process is utilised where there is no requirement to recover base metals from the concentrate. The alkaline process is suited to minerals such as pyrite, arsenopyrite, selenide, or telluride which have encapsulated precious metals.

Refractory gold bearing sulphides, such as pyrite, liberate both iron and acid when oxidised. In the alkaline process, this iron and acid is continually neutralised and precipitated from the leach by the addition of an alkali such as limestone. The continual removal of the leach reaction products from solution means that the leach progresses rapidly and very high levels of sulphide oxidation can be achieved. Ultrafine grinding of the minerals to minus 20 microns or less prevents passivation by these precipitated leach products, as the leaching minerals are consumed before a sufficient layer of precipitates can form.

The general leach reaction would be:



At the same time, carbonaceous minerals that might interfere with the gold recovery processes are rendered inert by the precipitation of gypsum and iron oxides on the carbonaceous surfaces. As the subsequent cyanidation stage occurs in alkaline conditions, there is no need to neutralise the leach slurry prior to cyanide leaching, and so CCD washing or filtration of the leach slurry is not required.

4. Comparison of Albion Process against Bacterial oxidation or Pressure oxidation on a North Queensland ore.

4.1 Project Parameters

For the purposes of the comparative study the project location chosen was green-fields Australia, with access to regional infrastructure. This would be representative of the North Queensland project, and would also illustrate the project economics in other similar locations.

The project scale chosen was 740,000 tonnes per annum (tpa) of ore with a feed grading 4.6 g/t Au and 11.6 g/t Ag. Bulk flotation of the ore produced an upgraded concentrate as feed to the oxidation stage at a rate of 18 tph, grading 22 g/t Au, 28 g/t Ag, 22% S, and 5% As. Gold production was up to 100,000 oz/yr Au, depending on the process recovery.

The study examined the production and treatment of this refractory sulphide gold concentrate by three different oxidation technologies to produce a cyanide leachable slurry suitable for gold recovery in a conventional CIL/CIP circuit.

4.2 Ore Mineralogy

The dominant host mineral in the ore sample tested in the work program was chlorite-clay altered, high-potassium quartz gabbro. Abundant coarse pyroxene was present, altered to chlorite and kaolinite. Minor host minerals included rutile and ilmenite.

Sulphides were widely disseminated in the host rock, in silicified wall rocks, and also occurred in veinlets. Subhedral-anhedral <0.5 mm pyrite (5 vol%) was the commonest sulphide, and occurred in the least silicified host rocks, whereas <150 micron subhedral arsenopyrite (1 vol %), the other major sulphide in the ore, was concentrated in the quartz veins, the siliceous wall rock, and in siliceous alteration patches. No free gold was found, suggesting that a significant amount of the gold was present as submicroscopic gold in arsenopyrite.

4.3 Test Results

Bench scale test work conducted at Hydrometallurgy Research Laboratories demonstrated the following recoveries and consumable requirements from the North Queensland ores:

Table 1 - Process Test Results and Consumable Requirements

Process Parameters	Albion Process	Pressure Oxidation	Bacterial Oxidation
Leach recovery - Au %	92	94	78
Leach recovery - Ag %	75	4	25
Leach oxidation - sulphide %	70	96	65
Baseline Leach recovery – Au %	42	Concentrate as received 80% passing 100µm	
Baseline Leach recovery – Ag %	6		
<u>Consumables</u>			
Oxygen tpa	62,357	82,000	0
Limestone tpa	83,818	111,757	111,427
Lime tpa	14,209	6,824	2,069
(NH ₄) ₂ SO ₄ tpa			1,480
H ₃ PO ₄ tpa			296
KOH tpa			814
Antifoam tpa			74
Flocculant tpa		3.8	
Sodium cyanide tpa	1,500	394	1,931
Activated Carbon tpa	18	7	5

4.4 Process description

4.4.1 Albion Process

4.4.1.1 Block flow diagram

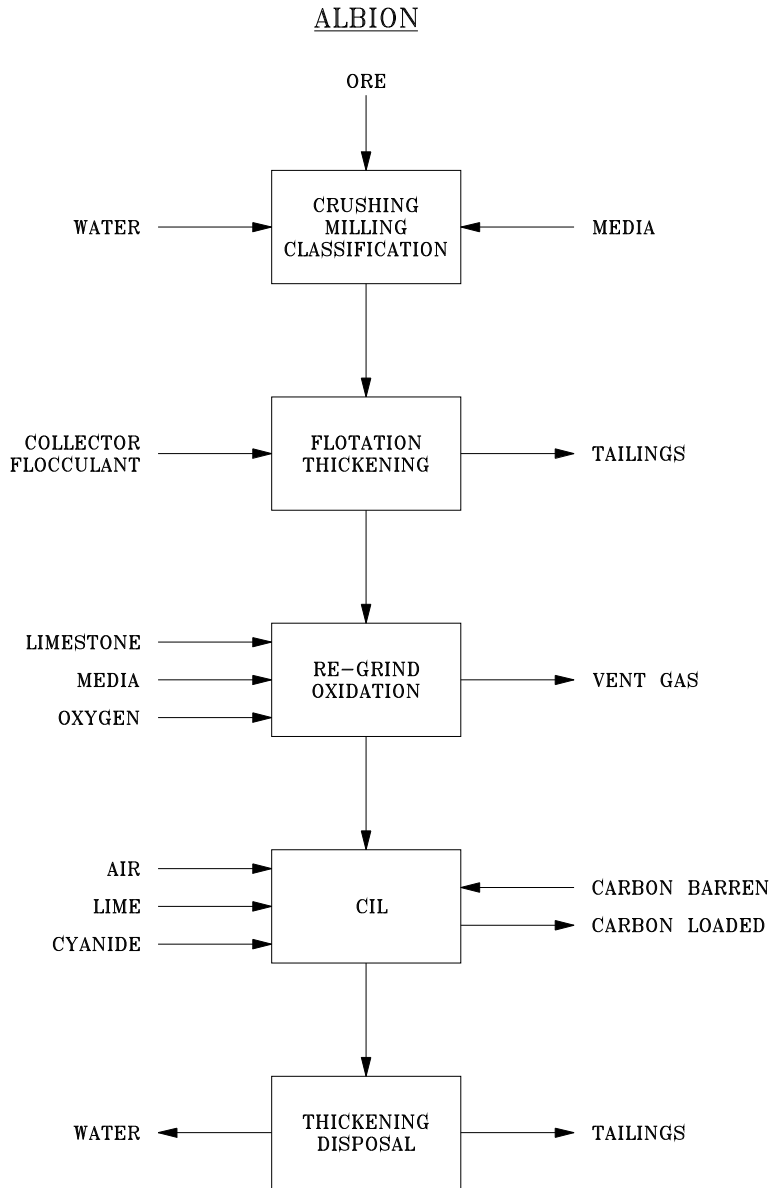

4.4.2 Pressure oxidation

4.4.2.1 Block flow diagram

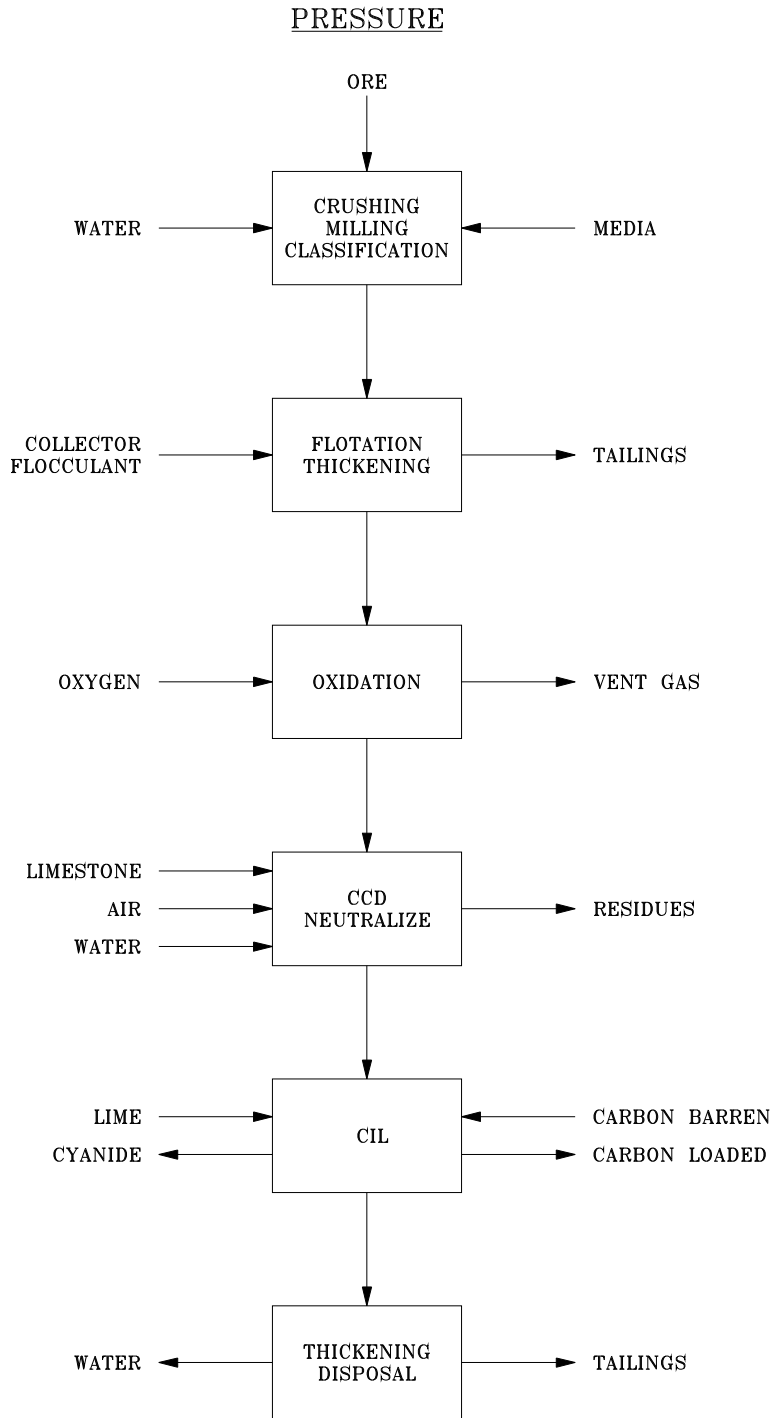

4.4.3 Bacterial oxidation

4.4.3.1 Block flow diagram

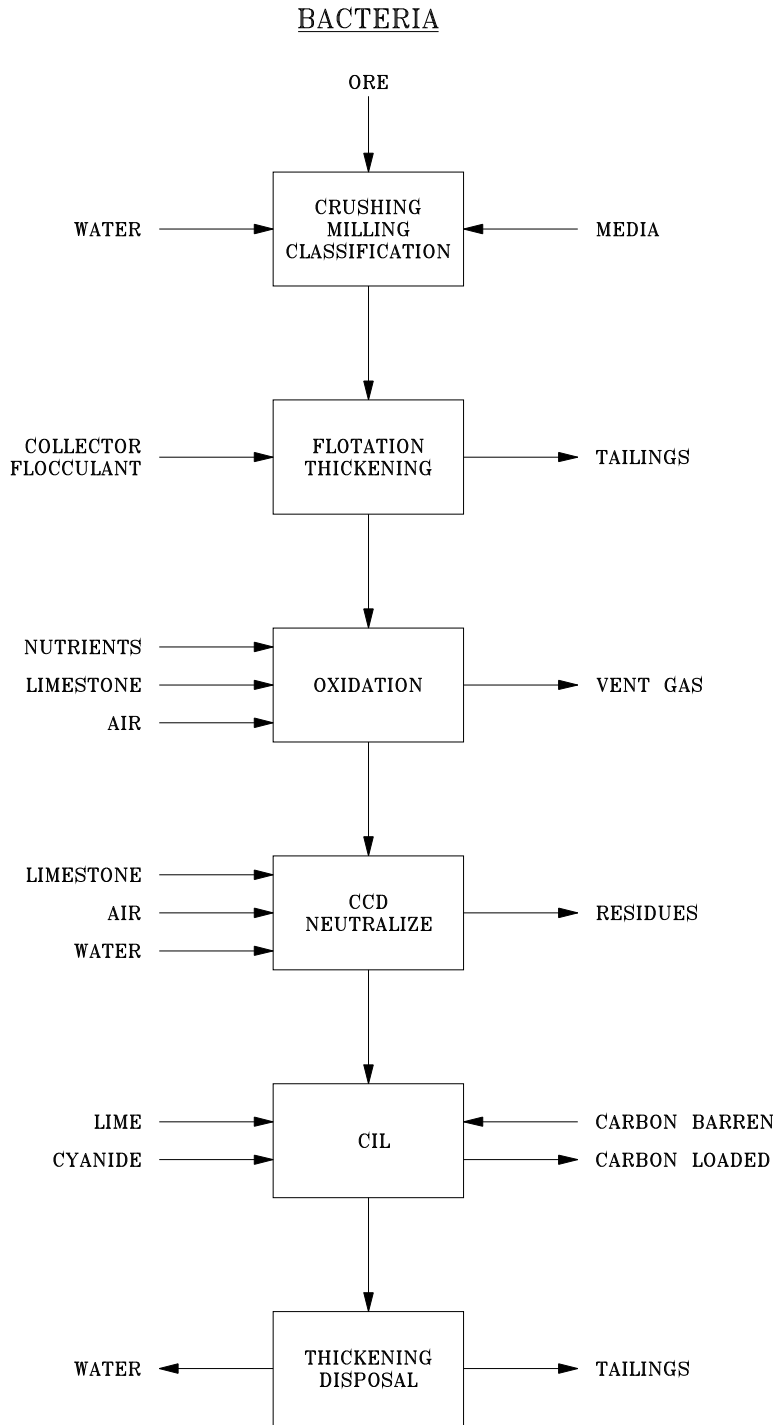

4.5 Capital Cost Estimate

4.5.1 Basis of Estimate

This order of magnitude estimate has been prepared to a “Class 1 – Conceptual” standard as defined by AKA, which is considered to be -30%/+50%. Capital costs are estimated at September 2004 and to not capture 2005 escalation of labour and materials. The scope of the direct cost estimate for the three options includes capital for the process facilities only.

The process plant estimates were developed by factoring from similar areas in other recent gold project estimates, and adjusted for size, flow or capacity. Currency exchange rates at September 2004 were assumed for this comparison of the metallurgical treatment options.

The estimates reflect installed costs in a green-fields location with access to regional infrastructure, illustrative therefore of North Queensland and of similar locations. Equipment costs cover instrumentation and control, electrical equipments, structural and concrete, piping and fabrication costs and installation. A contingency allowance of 10% was applied to direct costs to reflect only the conceptual scope uncertainty.

The summary of the capital costs is shown in Table 1. Costs are presented in Australian dollar (A\$) values.

4.5.2 Capital Costs Exclusions

The capital cost has been presented to show the relative direct capital cost for the various process facilities. The following items are excluded from the estimate as the level of scope development is conceptual:

- Utilities and reagent supply outside the process plant,
- General infrastructure,
- Capital spares for first year of operation
- EPCM and vendor supervision,
- Heavy crantage, temporary facilities and site distributables,
- First Fill consumables and warehouse stocks,
- Insurances, technology licences and tariffs,
- Construction camp and mobilization,
- Mining and haulage of ore and limestone to the process plant,
- Tailings dams and effluent disposal,
- Sustaining, replacement and deferred capital,
- Assistance during commissioning, ramp up and operation,
- Working capital requirements and owners costs.

4.5.3 Methodology

The capital costs for each process block were generally factored directly from previous AKA projects or recent studies as most appropriate. The reference projects were selected for similarity of equipment and adjusted for flow capacity and currency movements.

The capital cost for the CCD and Neutralisation process block, (not part of the Albion Process flowsheet) was factored from an AKA Study, (May 2003). Differences in the downstream process including gold recovery were also factored on the basis of their respective metallurgical and operational criteria.

Albion Process

The capital cost for the Albion Process block was factored from an AKA study which compared the Albion Process with roasting, (August 2004). The process criteria for oxygen consumption efficiency and reactor retention were applied to obtain the factored costs. The capital cost for an oxygen plant is not included because of through the fence supply allowance captured in the operating costs.

Pressure Oxidation

The capital cost for the Pressure oxidation process block was factored from a recent AKA gold pressure oxidation study (May 2003) allowing for currency movements. The process criteria for oxygen consumption efficiency, feed pumping and reactor retention were applied to obtain the factored costs. The capital cost for an oxygen plant is not included because of through the fence supply allowance captured in the operating costs.

Bacterial Oxidation

The capital cost for the Bacterial oxidation process block was factored from a recent AKA gold Bacterial oxidation study having equivalent tank and agitator configuration. The cost of the air blowers, slurry cooling and other ancillary equipment was calculated from the AKA database. The process criteria for air demand and dispersion, and reactor retention were applied to obtain the factored costs.

4.6 Operating Cost Estimate

4.6.1 Basis of Estimate

This order of magnitude estimate has been prepared to a “Class 1 – Conceptual” standard. Operating costs are estimated at December 2004, and do not capture 2005 escalation of labour and consumables. Comparative operating costs were developed for major expense categories including;

- Labour
- Utilities
- Consumables and reagents
- Maintenance

Each category was broken down by item sufficiently to allocate rates and prices. The costs are based on the “back-end” of the process facilities as shown in the block flow diagrams (see section 4.3). The costs to operate the front end facilities of crushing, milling and flotation are largely identical and not considered in this comparison.

- Concentrate treatment rate; 18 tonnes per hour
- Concentrate grade; 22% sulphur and 22g/t gold
- Operating hours; 8200 per year approximating 94% availability

Prices for reagent utilities were obtained from supplier inquiries or the AKA database. The consumption rates or quantities were derived from mass balances from the testwork or interpreted from studies of similar projects by AKA. The cost of oxygen was based on a dedicated facility for supply ‘through the fence’ from a supplier quotation.

Labour allocations were nominated for the concentrate treatment facilities including neutralization and CIL requirements based on other recent studies. Salaries or wages were estimated from in-house information for Australian projects.

Maintenance costs were factored against direct equipment costs based on ratios from similar processing facilities. Power and water costs were developed from estimates of area consumer and a power cost of 5 c/kWh was used.

The following items are excluded from the operating cost estimate;

- Management of residue impoundment and rehabilitation
- Regulatory and licence costs
- Head office costs and site security
- Product transport, refining and royalty charges
- Insurances and statutory inspections
- Amortization, depreciation and financing
- Ore comminution and concentrate production

The costs presented for the process facilities are relative and capture direct operational expenses only for the oxidation and downstream operations. The costs are considered at conceptual scoping level.

All costs are presented in Australian dollars with values current at September 2004.

4.7 Summary of Comparative Cost Estimates

The comparative capital and operating costs are presented and discussed below. Preliminary comparisons can be made on a relative basis. Capital costs for the process facilities are shown in Table 2, and include estimates for the concentrate production to show their relative magnitude against concentrate treatment (highlighted in grey). Operating costs are summarised in Table 3 for concentrate treatment including oxidation leaching, neutralisation and washing, followed by CIL treatment of oxidised concentrates.

4.7.1 Capital Cost Comparison

Table 2 - Process Facilities Direct Capital Cost Estimate Summaries

Area Description	Albion Process	Pressure Oxidation	Bacterial Oxidation
Crushing and Grinding	15.4	15.4	15.4
Flotation and Concentrate Thickening	4.0	4.0	4.0
Oxidation	10.5	25.3	29.8
CCD and Neutralisation	-	2.5	3.0
CIL, Gold Recovery and Cyanide Detox	1.7	1.0	1.1
Contingency 10%	3.2	4.8	5.3
PROCESS TOTAL A\$M	34.8	53.0	58.6

The Albion Process concentrate treatment facilities are estimated to have substantially lower capital cost than the other process routes, i.e. \$12.2M compared to \$28.8M for Pressure oxidation and \$33.9M for Bacterial oxidation. The direct capital savings are in the order of \$16M and \$22M respectively (excluding contingency).

These estimated differences in capital costs can be viewed in terms of the total capital needs that may be around \$100M-\$150M for a typical 100,000 oz/yr green-fields, refractory, gold operation in Australia. Total project costs will be influenced by infrastructure requirements and mine development, but this potential saving is substantial at the conceptual accuracy of the estimate.

The lower cost for Albion Process plant and equipment can be attributed to smaller reaction tanks and agitators compared to Bacterial oxidation, while the pressurized Pressure oxidation operation requires substantially more expensive equipment. The amount of installed exotic piping and complexity of control would also be substantially less for an Albion Process oxidation facility.

4.7.2 Operating Cost Comparison

Table 3 - Concentrate Treatment Operating Cost Estimate Summary

Item	Albion Process	Pressure Oxidation	Bacterial Oxidation
Labour	1.7	3.5	2.1
Utilities	2.2	1.6	3.3
Reagents	9.3	6.3	7.7
Maintenance	0.9	2.1	1.3
Concentrate Treatment Annual Operating Cost A\$M	14.1	13.5	14.5
Cost per Ounce Produced A\$	147	138	178

Concentrate treatment operating costs for the Albion Process plant, \$14.1M pa are similar to the Pressure oxidation facility, \$13.5M pa with the conceptual accuracy of the estimates. The slightly lower unit cost for Pressure oxidation is indicative of the incrementally higher gold recovery predicted following this aggressive leaching route. The supply costs for oxygen is the major, variable expense items for the Albion Process and Pressure oxidation process flowsheets.

Slightly higher total operating costs are estimated for the Bacterial oxidation process, \$14.5M pa compared to Albion Process concentrate treatment. The major variable cost difference arises from the air supply and dispersion power demand for Bacterial oxidation compared to oxygen consumption in the Albion Process reactors. The lower gold recovery from the testwork results in substantially higher unit costs for operating the Bacterial oxidation flowsheet.

The Albion Process plant is estimated to have the lowest labour fixed cost due to the relative simplicity of operation and maintenance. The Bacterial oxidation plant requires closer monitoring by operators to maintain bacterial activity, and has more ancillary facilities, e.g. neutralization and water cooling. The Pressure oxidation plant is expected to have greater process control requirements and higher maintenance workforce due to the more aggressive operating conditions. The additional cost of these complexities will depend on the remoteness of the plant location from major population centres and the availability of skilled labour.

4.7.3 Total Concentrate Treatment Cost Comparison

Table 4 summarises the total concentrate treatment costs including amortising the capital costs for the various oxidation technologies. The costs used covered the process plant from concentrate oxidation to cyanidation of the leach residue.

Capital costs that were amortised included the direct costs for concentrate treatment from Table 2 (highlighted in grey) with 10% contingency and 20% indirect costs added. The total capital costs including contingency and indirect costs for concentrate treatment for the three processes are as follows; Albion Process - \$16.1M, Pressure Oxidation - \$38.0M and Bacterial Oxidation - \$ 44.8M.

Capital costs were amortised at 15% per year.

**Table 4 - Concentrate Treatment Operating Cost Summary
(including Capital charge)**

Item	Albion Process	Pressure Oxidation	Bacterial Oxidation
Operating Cost per Ounce Produced A\$	147	138	178
Capital Cost Amortised per Ounce Produced A\$	25	58	83
Total Cost per Ounce Produced A\$	172	196	261*

* Total costs for Bacterial oxidation would reduce to \$219/oz, if the gold recovery achieved was the same as the Albion Process (ie 92%)

5. Process Options Comparison

5.1 Operability

The major attractions of the Albion Process compared to other refractory concentrate treatment routes include the simplicity of operation and lower capital cost. All equipment for Albion Process will have conventional and proven designs, and would be smaller than Bacterial oxidation facilities of equivalent concentrate capacity. The process control and monitoring demands for the Albion Process equipment are expected to be simpler than all other competing technologies including Bacterial oxidation, Pressure oxidation, roasting and chlorination.

Start up and shut down are rapid for Albion Process facilities unlike Bacterial oxidation or Pressure oxidation reactors. No equipment or operational risks arise from loss of temperature or pressure that may be experienced in roasters or Pressure oxidation plants. Loss of power, oxygen or air supply presents no major difficulties to the process efficiency or upon a re-start.

The stable nature of the Albion Process allows operators to learn to control the operation quickly and reliably. Personnel with limited process backgrounds can be taught to run the plant optimally in a short time frame. The operational duties are expected to be shared by the CIL operator in most facilities, thus keeping labour costs at a minimum.

5.2 Availability

High run time availability of 94% or better is expected from the Albion Process plant area, which is higher than most milling facilities and other refractory ore treatment plants.

The equipment in the Albion Process plant has conventional design and common materials of construction. The layout and piping configuration can allow for individual equipment bypassing while concentrate treatment continues.

5.3 Flexibility

The Albion Process is able to deal efficiently with all occurrences of refractory concentrates; sulphides, arsenides, or carbonaceous. The ultrafine grinding and effective oxygen uptake allow variable feed grade treatment. The nature of the precipitated iron and sulphur species in the Albion Process leach residue promotes low cyanide consumption in downstream gold recovery.

The presence of base metals and organic contaminants in concentrates are accommodated by the Albion Process. The extent of oxidation achieved in the Albion Process leach is a function of residence time, and is relatively insensitive to mineralogy. As the leach is not bacterial, it does not require the addition of nutrients to the leach, and metals or organic contaminants that may limit bacterial activity will not affect the Albion Process leach.

Volatile metals such as mercury are not volatilised at the operating temperatures of the Albion Process leach, and report to the residue. Toxic metals such as arsenic will report to the leach residue in an environmentally stable form, as ferric arsenate.

5.4 Maintainability

The application of simple proven process steps, conventional equipment and accessible plant layouts contribute to easily maintainable plant. The smaller tank size and the benign slurry conditions used in the Albion Process leach allows improved access and lower maintenance costs compared to Bacterial and Pressure oxidation facilities. The Albion Process flowsheet also avoids CCD and separate neutralization sections completely, and so the overall maintenance workload will be minimal compared to Pressure oxidation facilities.

The generally alkaline slurry for precious metals treatment in the Albion Process largely negates the need for high grade stainless steel throughout the plant. The use of exotic nickel alloys or titanium are not required for the Albion Process facilities.

Special surface preparations, frequent inspections and operational contingencies that are prevalent for expensive materials are not required at the Albion Process operating conditions.

5.5 Effluents and Emissions

Slurry discharge from the Albion Process would be further treated through a conventional CIL flowsheet for gold recovery. The final residues can then be handled and stored in impoundments or mine-fill following standard cyanide detoxification. No other liquid effluents arise from the Albion Process flowsheet.

Gaseous emissions from the Albion Process leach tanks are minimal due to the high oxygen utilization. Residual oxygen, and carbon dioxide that arise from in-situ neutralization, will be saturated in moisture. Beside the vapour plume dispersion no gas cleaning will be required to remove acid mist or volatile components.

5.6 Gold/Silver Recovery

Albion Process testwork on a variety of ores has achieved gold recoveries generally comparable to Bacterial oxidation, however in this instance it was higher. Pressure oxidation can release incrementally higher levels of gold due to the higher temperature and pressure involved.

A key benefit of the Albion Process is that in every instance tested to date it has achieved significantly higher silver recoveries than Bacterial oxidation and Pressure oxidation.

5.7 Reagent Consumption

The gold is recoverable following Albion Process leaching by conventional CIL/CIP processing at relatively low cyanide and lime consumptions. Limestone consumption will be similar for all oxidation process routes as dictated by the level of sulphur oxidation. Cyanide consumption in the CIL/CIP plant is lower than Bacterial oxidation due to the nature of the leach residue. The Albion Process uses lower levels of neutralising agents for some concentrates as some elemental sulphur is produced.

Nutrient, flocculant or dispersion reagents are not needed for Albion concentrate treatment. Low cost grinding media is needed for fine grinding of concentrate in IsaMills

Oxygen demand by the Albion Process is expected to be similar to that needed on Pressure oxidation reactors. For this study an oxygen utilisation of 80% was used for Pressure oxidation and the Albion Process reactors. The consumption in Pressure oxidation will depend on the concentrate mineralogy, including the carbonate assay.

6. Current Process Options

A plethora of concentrate treatment flowsheets have been promoted over the last decade for both base and precious metals. Novel leaching options for gold, nickel and copper sulphide concentrates may be compared to the Albion Process based on the intensity of process conditions.

A number of concentrate leaching processes have been developed to piloting or beyond, these are listed in table 5. Other processes that do not use air or oxygen as the primary oxidant have not been listed. It should be noted that many of these processes have emerged specifically to treat copper concentrates but are included as they may be adapted to mixed copper/gold concentrates or gold concentrates

Table 5 - Proposed Routes for Sulphide Concentrate Leaching

Parameter	High	Moderate	Low or Ambient
Temperature, celsius	>155	115-155	<115
	Pressure oxidation	AAC/UBC CESL Dynatec	Albion Process Activox Mt Gordon Bacterial oxidation
Pressure, pascal	>1M	150k-1M	<150k
	Pressure oxidation AAC/UBC CESL Dynatec	Activox Mt Gordon	Albion Process Bacterial oxidation
Retention, hours	>24	1-24	<1
	Bacterial oxidation	Albion Process Mt Gordon Activox	Pressure oxidation AAC/UBC CESL Dynatec
Grind Size, P80 microns	<38	38-75	>75
	Albion Process Activox AAC/UBC	Bacterial oxidation CESL Dynatec	Pressure oxidation Mt Gordon

The Albion Process is designed to operate at ambient pressure and relatively low temperature. This arrangement allows concentrate oxidation to be conducted in conventional agitated tanks which allow the construction costs to be minimized. Bacterial oxidation is the only other mentioned process that operates at these low intensity conditions. The Bacterial oxidation process requires about 5 days retention compared to approximately 1 day for the Albion Process.

The Bacterial oxidation reaction time will decrease marginally as the grind size decreases and the leach temperature rises but is unlikely to drop below 4 days. After concentrate treatment by Bacterial oxidation the metal recovery is likely to be lower while the reagent consumptions will be higher relative to the Albion Process plant.

Control of Bacterial oxidation can become problematic at higher slurry temperature due to fluctuating activity of more specialized thermophilic bacteria.

The Albion Process and Pressure oxidation process are the only routes to have been shown to operate in alkaline slurries. Lower cost materials of construction are expected to be installed compared to acid slurries, particularly at the lower temperature of operation.

7. Conclusions

A number of refractory gold processing technologies are currently available. However, the Albion Process now offers the gold mining industry a simpler, robust, and lower cost alternative for treating these ores.

The technology has been extensively tested at large pilot plant scale on a number of different ores and a qualitative comparison of the main process factors shows that the Albion Process conditions are technologically robust and potentially less complex to build and operate.

The study provided some compelling evidence into the cost benefits of the Albion Process. These benefits along with lower capital exposure and simple commissioning make the Albion Process worth considering.

Core Resources is currently working with potential partners to bring the first Albion Process plants into production.